



5000 SERIES

BUILDING MAINTENANCE UNITS

**LEADING PROVIDER OF PREMIUM
FACADE ACCESS SOLUTIONS**



Tianjin Chow
Tai Fook Financial Center
(Tianjin, China)

Introducing the CoxGomyl 5000 Series

The CoxGomyl™ 5000 Series range of Building Maintenance Units provide the ideal choice of facade access solutions for buildings of moderate complexity, offering solutions beyond the standard configurations available within the 3000 Series.

The 5000 series products are available in two ranges, the standard and flexible.

Standard range (S): A limited, premium quality range of the most frequently requested options. This range is the ideal choice for building facades of moderate complexity with heights up to 280 metres.

Flexible range (F): Our optimum solution providing a wider range of flexible and modular options to be utilised for a wide range of facades with heights up to 500 metres.

The two ranges within the 5000 Series provide a diverse offering of facade access solutions for buildings of moderate complexity and make up the majority of CoxGomyl's project portfolio due to the modularity of the series.

For more complex and unique access requirements that require further customisation beyond that offered by the 5000 series, CoxGomyl's engineering team can devise a custom facade access project utilising a dedicated engineering and project management team to provide the most suitable solution.

The 5000 series is fully manufactured in Europe under stringent high-quality standards and implemented in our manufacturing facilities.

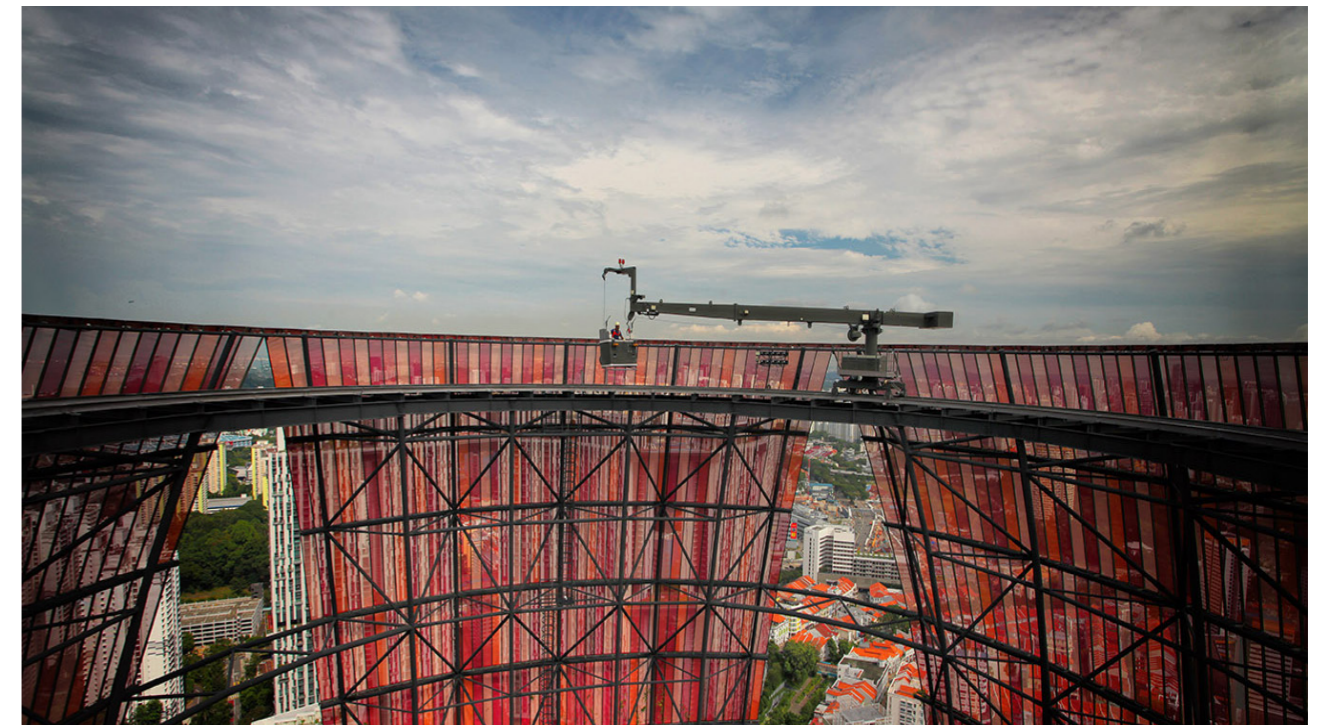

Oasia Hotel, Singapore

5000 Series — Standard Range

The Standard range of building maintenance units provides a limited yet premium quality range of the most frequently requested options. This range is the ideal choice for building facades of moderate complexity.

The CoxGomyl 5000 Series Standard building maintenance units are designed from consistent components that are rigorously tested across a wide range of building types and offer a maximum reach of 30 metres, with heights up to 280 metres.

Each component has been updated and optimised to reduce the total weight, creating minimum impact to the building structure design and providing enhanced safety, a quicker installation and easy maintenance.

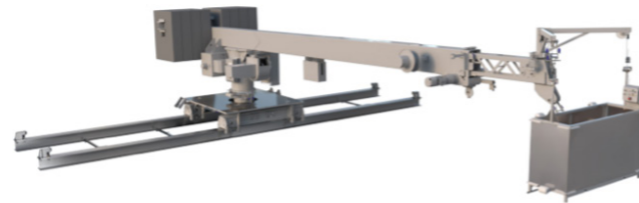

- The Standard model is typically installed on a building with a flat roof
- Its range and competitive price make this model the ideal option for buildings of moderate complexity up to 280 metres
- Equipped with CoxGomyl's multi-layered hoist mechanism which can comply with any industry requirements
- Manufactured in Europe

Key Features:

- Building height up to 280 metres
- Customizable reach up to 30 metres
- Four cradle lengths available
- Equipped with CoxGomyl's multi-layered hoist mechanism which can comply with any industry requirements
- Fixed or traversing subframe
- Optional remote monitoring capabilities with live data insights

Ask our sales representative for more information or download the **5000 Standard Specification Sheet**

<https://www.coxgomyl.com/products/building-maintenance-units/moderate-complexity-5000-series/>

5000 Series — Flexible Range

The CoxGomyl 5000 series Flexible range of building maintenance units provide a wider range of flexible and modular options to be utilised for a range of facades with a maximum reach of 45 metres, with heights up to 500 metres.

The 5000 Series Flexible range offers a slightly more customised offering than the standard range, developed by our highly experienced engineering team from an extensive library of installed global facade access projects from CoxGomyl.

The flexible models have been developed using a range of rigorously tested modular components to provide the safest possible access to the facade for a wide range of facade types.

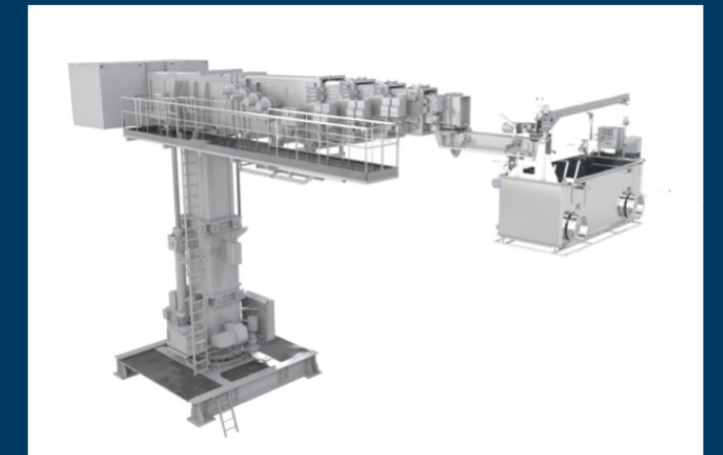

- The Flexible model can be installed on a building with flat or sloped roofs and operate on positive and negative facades
- The modularity and extended range of solutions make this model ideal for almost all building types
- Equipped with CoxGomyl's multi-layered hoist mechanism, which can comply with any industry requirements
- Manufactured in Europe

Key Features:

- Building height up to 500 metres
- Customizable reach up to 45 metres
- Fixed or traversing subframe
- Able to be installed on sloped roofs
- Any cradle dimension under request
- Special approaching system available
- Optional remote monitoring capabilities with live data insights

Ask our sales representative for more information or download the **5000 Standard Specification Sheet**

<https://www.coxgomyl.com/products/building-maintenance-units/moderate-complexity-5000-series/>



International Youth Cultural Centre, China

5000 Series Options

Depending on your facade access requirements, CoxGomyl's building maintenance units can be modified with different mounting options, parking systems, machine movements, cradles, and facade restraint options.



Torre Caja, Spain

Roof Integrations

- Fixed
- Traverse movement
 - Trackless
 - Guided angles
 - Twin track
 - Hidden U profile

Parking systems

- Pantograph system
- Luffing jib
- Folding jibs
- Lifting tables
- Telescopic mast

Suspended platforms

Suspended platforms, also known as cradles, can be configured according to your requirements with variable sizes in length and depth and with several system approach mechanisms (SAM) to enhance safety.

5000 Series Options

Facade restraint options

- ISA pins with restraints
- Soft rope
- Pull in system
- Mullion guides

Additional options

- Mobile counterweight
- Slopping facade integration
- Knuckle jib
- Auxiliary hoist for goods lifting
- Bi-jib design

Safety Features

The CoxGomyl cradle will be equipped with the following safety features as standard.

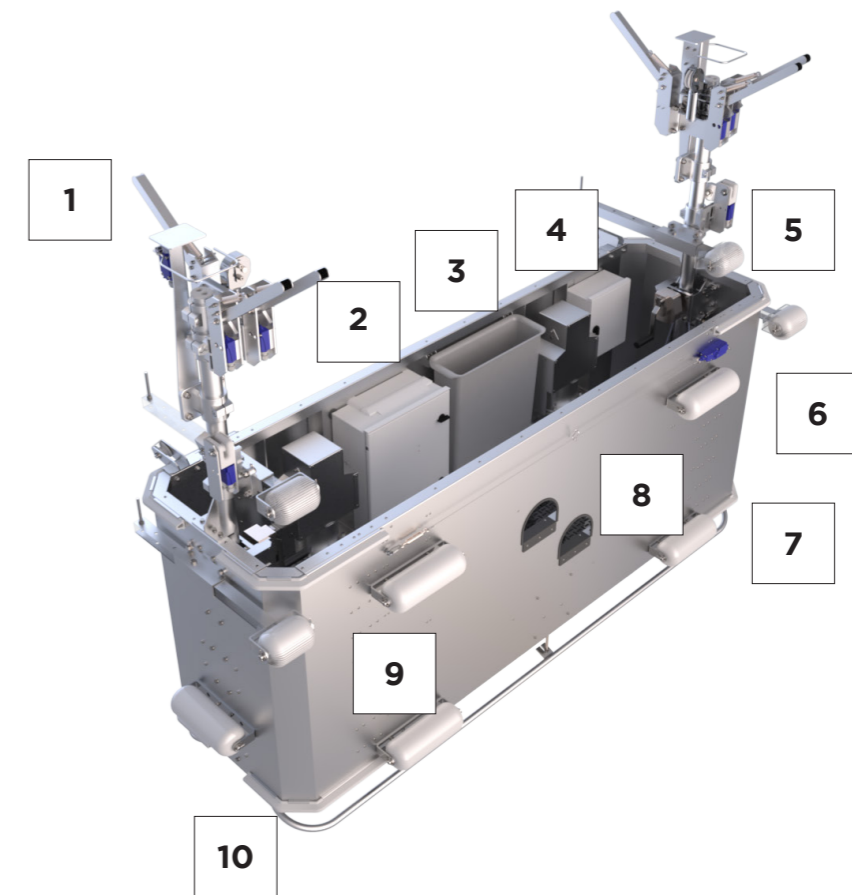

1. Upper trip bar
2. IP 55 control panel as standard
3. Extra large water tanks
4. Telephone box
5. Telescopic soft rollers
6. Upper and bottom soft rollers
7. Castor wheels under the cradle
8. Reinforced footsteps for a safe access
9. Extra light structure combined with aluminium panels
10. Protected corners
11. Anti-slip aluminium checkered plate
12. USB type A adapter

All of our carbon steel parts included in our BMUs are hot dip galvanized according to EN 1461 and manufactured in Europe. The Welding procedure is according to EN ISO 15614 with approved personnel as per EN ISO 187-1 and EN ISO 9606-2.

MyBMU – Remote Monitoring Platform

MyBMU is a customised web-based portal developed by Alimak Group to enhance the safe and efficient use of facade access systems from CoxGomyl. The remote monitoring portal provides users with up-to-date information on their facade access equipment from CoxGomyl.

The portal displays various operational information, with data collected and displayed in an easy-to-read format. The benefit of this data is immense to support the overall asset management for owners by anticipating necessary maintenance and repairs as required, enhancing safety, ensuring maximum product uptime, and minimising downtime due to repairs.

What is MyBMU?

This new tool will provide vital data insights on equipment, eliminating the guesswork of predicting maintenance requirements for building maintenance units. Information such as the number of starts and hours in operation provides owners with an accurate analysis of how the equipment is utilised.

The MyBMU portal provides the maintenance team, operators, and product owners with access to:

All standard machine information, including the latest technical documentation, certificates, and potential safety bulletins.

- Operational manuals and quick interactive guides
- Access to online training courses
- Machine status position of the building maintenance unit
- Service information and easy access to support
- Remote support from our service organisation
- Statistics of machine usage – hours, drops and coverage of the facade
- Easy to use reporting system for damages to the facade

How does it work?

- MyBMU is empowered via remote monitoring of state-of-the-art PLC systems utilised in CoxGomyl building maintenance units (BMUs).
- The products are equipped with a router to send data from the BMUs and are certified to ISO 27001, the internationally recognised standard for information security.



BIM Gallery

Save time to find the ideal facade access solution for your building project. Our range of Building Information Modelling (BIM) object files allow you to compare and select the most suitable product for your needs.

The Facade Access BIM Gallery contains 3D models with key embedded information of our building maintenance units including capacity, reach, space requirements etc. The BIM models can be configured to your needs. By utilising the BIM models at the planning phase of your project you can optimize and simulate the use of our products throughout the project and thereby reduce potential risks that can be difficult to foresee in a 2D environment.

Models can be viewed online by using [Autodesk Viewer](#), which requires an Autodesk account.

For the CoxGomyl 5000 Series Flexible range, a customised BIM file will be provided to you to fit the unique solution for your building. Please contact a sales representative for more information.

View the Gallery by scanning this QR code.



manntech COX GOMYL

Facade Access BIM Gallery

Save time to find the ideal facade access solution for your building project. Our range of Building Information Modelling (BIM) object files allow you to compare and select the most suitable product for your needs.

Manntech and CoxGomyl's Facade Access BIM Gallery contains 3D models with key embedded information of our building maintenance units including: capacity, reach, space requirements etc. The BIM models can be configured to your needs. By utilising the BIM models at the planning phase of your project you can optimize and simulate the use of our products throughout the project and thereby reduce potential risks that can be difficult to foresee in a 2D environment.

For more information or enquiries email: bim.support@alimakgroup.com

- 1000 SERIES
- 3000 SERIES
- 5000 SERIES

What makes a building complex for facade access and maintenance?

Complex buildings and structures require superior building maintenance and facade access solutions that meet architectural requirements and ensure building upkeep.

There are a range of variables and building features that can increase the complexity in providing facade access solutions for building structures.



20 Fenchurch Street, UK

Unique architectural design

Architects, consultants, constructors, and owners often face complicated facade challenges. From mega-tall buildings, unusually shaped structures, or intricate facades with protrusions, slopes, recesses, curtain walls or curves, the CoxGomyl design and engineering team have a solution as one of the few facade access providers worldwide to design innovative facade access solutions for architecturally complex building structures.

Limited roof space

Building roof tops can vary in size, shape and available space such as sloped roofs, or including building facilities such as elevator rooms, air conditioning equipment, water tanks and solar panels. These additional features can leave limited space to position facade access systems or a clear path for traverse movements. Also of importance is ensuring the architectural aesthetic is maintained. The design team can suggest various solutions to park or store facade access systems out of sight when they are not in use.

Leisure purposes: As urban development grows, rooftops are increasingly being used to provide residential leisure and meeting areas such as roof top gardens, lounge areas and even swimming pools. These functional elements also limit the available roof space. CoxGomyl's design engineers can provide facade access solutions to accommodate urban rooftops.

CoxGomyl's solutions are developed to meet the individual requirements of each unique building, such as the features of the design, the technical limitations, and the practical necessities for the building's continued maintenance.

When deciding upon a technical solution, we consider various factors, such as the design of the roof, cleaning cycle, building footprint, BMU placement options, glass replacement strategies and emergency retrieval plans.

Service Solutions

Drawing on a global network, CoxGomyl offers local support in even the most remote locations with all operations carried out by qualified factory-trained service technicians.

The range of service and support solutions available from CoxGomyl include inspections, maintenance & repairs, training, genuine spare parts, asset management programs as well as refurbishment solutions.



SERVICE MAINTENANCE

A comprehensive range of service contracts, maintenance programmes and repair solutions



ASSET MANAGEMENT

A range of support solutions to manage the total life cycle of CoxGomyl and Manntech equipment



GENUINE SPARE PARTS

Genuine spare parts prolong equipment life and maximise performance



REFURBISHMENT SOLUTIONS

Bring new life to aging systems with a cost-effective refurbishment



TRAINING

Training to support the safe operation, maintenance and installation of equipment



INSPECTIONS, SAFETY & COMPLIANCE

Routine inspection programmes to ensure equipment is kept safe and compliant

CoxGomyl offer owners and operators of our equipment, tailored service maintenance agreements specific to their equipment requirements.

Service maintenance can range from ad-hoc maintenance to comprehensive service plans including spare parts and regular maintenance to maintain equipment throughout its lifecycle at a fixed annual cost. Utilising a global service support network, CoxGomyl can respond to callouts promptly.

A range of specific maintenance services are available for the specialised range of products from CoxGomyl, including fully powered building maintenance units, lift tables, monorails, power winch cradles, and fall arrest systems.



For more information visit www.coxgomyl.com

COXGOMYL and related logos are registered trademarks of Alimak Group AB (publ) and its subsidiaries ("Alimak Group"), in several jurisdictions, including but not limited to the EU and the United States. Alimak Group retains all rights in its name and for above mentioned trademarks, whether registered or not.

Copyright © Alimak Group. All rights reserved.