



3000 SERIES

BUILDING MAINTENANCE UNITS

**LEADING PROVIDER OF PREMIUM
FACADE ACCESS SOLUTIONS**



The 3000 Series is designed to provide reliable, economical facade access solutions for buildings of uniform shape, with time to manufacture within 12 weeks or less for any machine in the range.

Introducing the CoxGomyl 3000 Series

The CoxGomyl™ 3000 Series of machines is designed to provide reliable, economical facade access solutions for buildings of uniform shape, with time to manufacture within 12 weeks or less for any machine in the range.

As industry leaders and one of the only true end-to-end building access providers in the world, CoxGomyl have brought all of our experience and expertise in design, engineering and manufacturing in to developing this range of practical and cost-effective facade access solutions. By utilising standard components and configurations that will satisfy the access requirements for many buildings of uniform shape we are able to offer a high level of functionality and quality, combined with value and prompt delivery. Due to the lightweight

construction, the building maintenance units in this range are often suitable for replacing older, outdated access systems.

A set range of selection criteria has been defined to help in the identification of the most suitable product type at a high level. Operational options are also listed to assist in indicating the range of possibilities within the 3000 Series. It is recommended that you consult with a CoxGomyl design expert who can work with you on identifying the optimal cost-effective solution for your requirements.

The 3000 Series currently consists of 2 products, the E3000 and the F3000.



E3000

The E3000 Building Maintenance Unit (BMU) is a reliable and great value solution for buildings of lower height and uniform shape. A compact, robust and lightweight machine, the E3000 is almost entirely hidden from sight from ground level when not in use. Due to its compact profile, the E3000 machine is particularly well suited to applications with limited space on the roof and buildings with roof gardens. The system comes with the option of jib luffing with a minimum height of 1.1 metres, allowing for discreet parking. Simple to install and operate, the E3000 delivers a reliable, low maintenance and economical access solution with a range of safety features such as upper and lower safety bars on the platform and a auxiliary hoist for replacement of facade elements such as windows.

Standard Features

- 2m aluminium cradle
- Full galvanised finish
- Rollers or telescopic wheels on platform
- Full range of safety features (see specification sheet)
- BMU weight < 6 Tons
- Install crane capacity required < 2 Tons
- Delivery in 12 weeks or less

Optional Features

- Range of colours available
- 22m cable reeler
- Luffing for parking
- Auxiliary hoist - 400kg max
- Painted counterweight
- Subframe platforms
- Track switch
- Detachable cradle
- Range of cradle components

Select if:

- Required outreach is up to 6m
- Building height is up to 135m
- Hidden parking is required - min. parking height is 1.1m
- The visual impact of the machine needs to be minimised. e.g. for Green Roof Buildings



Request the E3000 Specification Sheet for more information

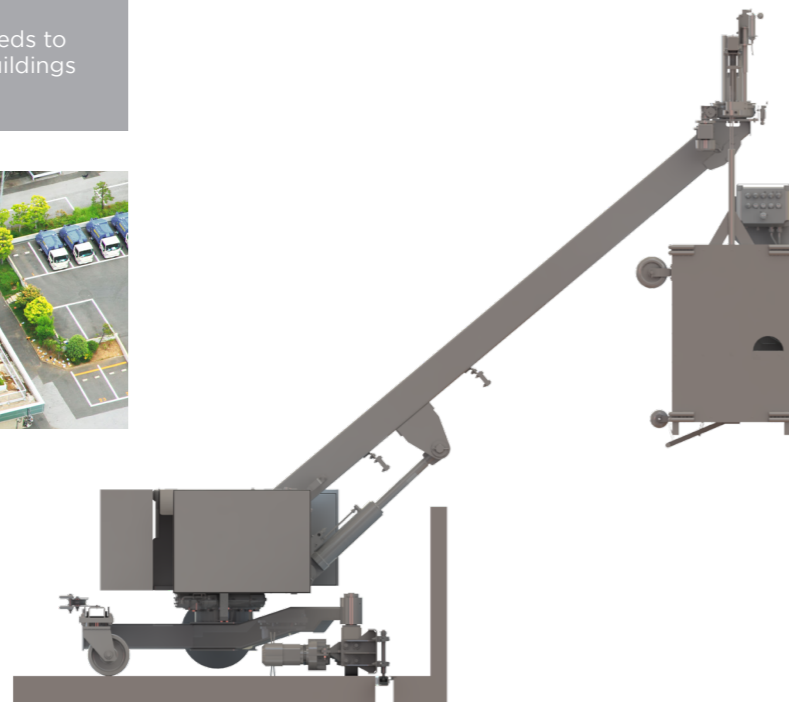

F3000

Often referred to as a 'crane type' Building Maintenance Unit (BMU), the F3000 is used when the reach or suspended load is increased beyond the capabilities of the E-type machines. This economical BMU has an impressive higher load capacity of 500kg for the auxiliary hoist and a reach of up to 14 metres, all of which can be delivered in no more than 12 weeks. Like the E3000 machines the F3000 features upper and lower safety bars on the platform and a glass hoist for window replacement. The F3000 is simple to install, safe to operate and adjustable in reach, drop and gauge. The F3000 is also suitable for replacements due to its lightweight, robust construction.

Standard Features

- 2m aluminium cradle
- Full galvanised finish
- Rollers or telescopic wheels on platform
- Full range of safety features (see specification sheet)
- BMU Weight max < 10 Tons
- Install crane capacity required < 2 Tons
- Delivery in 12 weeks or less

Optional Features

- Range of colours available
- Cable reeler (22m)
- Auxiliary hoist - 500kg max
- Painted counterweight
- Subframe platforms
- Track switch
- Anemometer
- Detachable cradle
- Range of cradle components

Select if:

- Required outreach is up to 14m from slew
- Building height is up to 240m
- Building shape and roof plan are simple
- Sub-assemblies with a weight less than 2 tons

Request the F3000 Specification Sheet for more information

Options available for the 3000 Series BMU's

Depending on your requirements CoxGomyl's standard 3000 Series range of products can be modified with a range of additional cradle and system components such as:

- Telescopic wheels
- Soft rollers
- Upper trip bars
- Castor wheels
- Telephone
- Range of frame colours

The Cradle

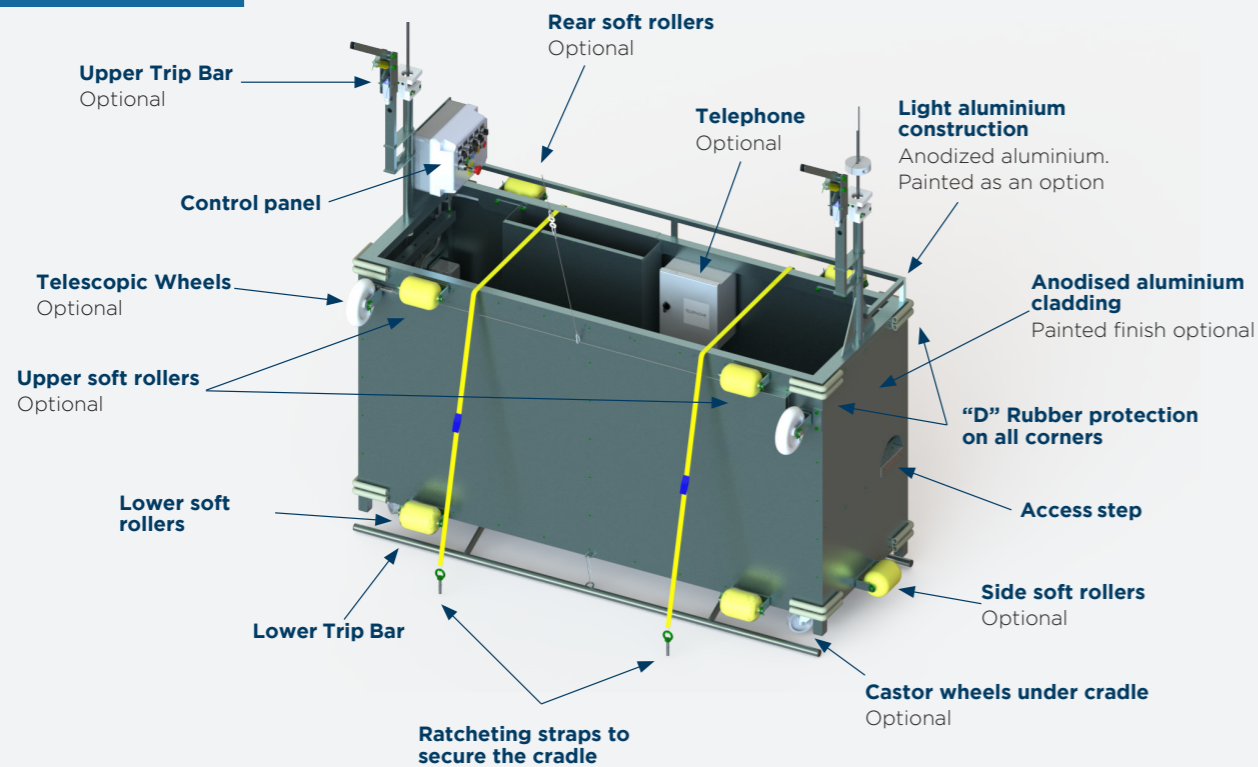

F3000

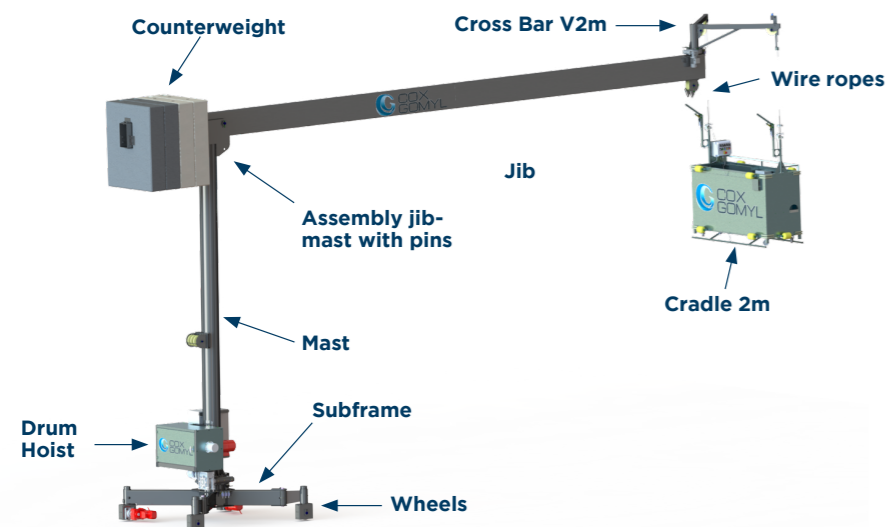

E3000

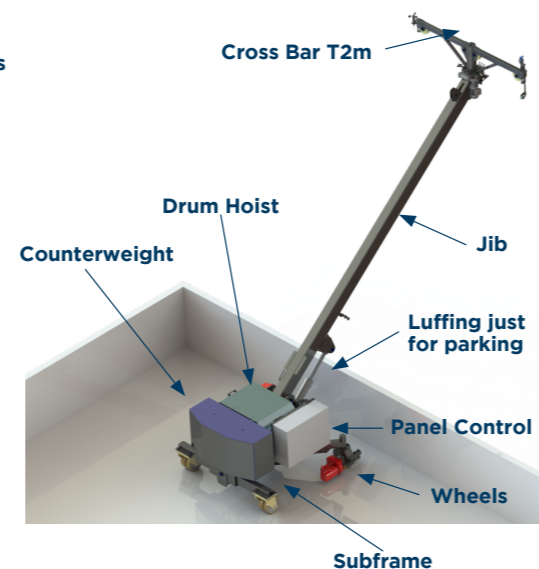

Our Services

We take responsibility for producing outstanding building and facade access solutions, and as such, are the largest full solution provider in the industry. CoxGomyl have experts in engineering, design, project management, implementation, safety and maintenance, to bring a complete 'end to end' spectrum of capabilities to your corner of the globe. This means we are ideally positioned to provide the economical solutions of the 3000 Series range and satisfy demands for fast delivery times.

Our expert team will work with you on final drawings and engineering calculations to ensure that all areas of the facade surface are reached, loads are understood and our project managers are integrating with your teams. From there the system will go into production and is seamlessly delivered and installed on the location.

CoxGomyl has been involved in thousands of building solutions over the past six decades in over 50 countries around the world. Our local and regional network of sales offices, project managers, and installation teams will work with you to deliver an installation that is smoothly executed, on time and on budget. After installing, we remain available to assist with the servicing and maintenance during the DLP period, as well as offering ongoing full maintenance and service packages.

There is a peace of mind that comes from having your long-life capital equipment maintained fully by the manufacturer. It ensures up time, a clean and well-maintained building, lower cost of ownership, and ultimately assists in the delivery of your value proposition with clients and tenants.

As a global leader our products can be designed to meet your local industry standards such as EN1808:2015 (European), GB19154.2003 (Chinese), SS CP 20/1999 (Singapore) or PB.10.518.02 (Russian).

If you would like to discuss the 3000 Series further, please contact your regional office (see overleaf for details). Remember to refer to the 1000 Series, 5000 Series and 7000 Series brochures if you feel you require an even simpler or more complex system than outlined within the capabilities of the 3000 Series range. With such a vast product range and every buildings being different, we recommend you consult directly with a CoxGomyl Sales Advisor, who can assist in developing the optimal solution and the smooth end-to-end planning and execution of your project on time.

Both the E3000 and F3000 are available with a range of wheel options to suit your project requirements.

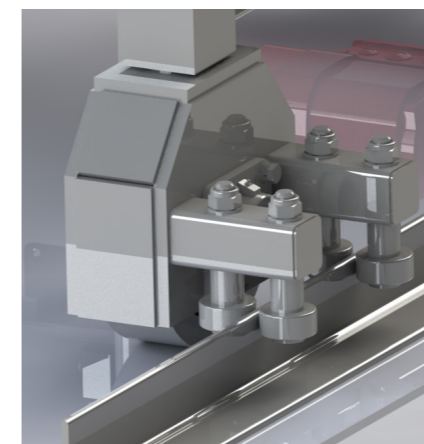

L Front Guided Wheel

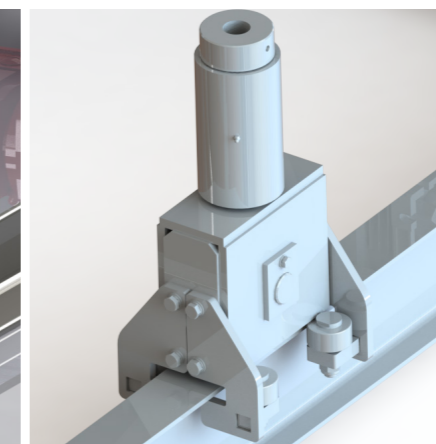

Twin Track

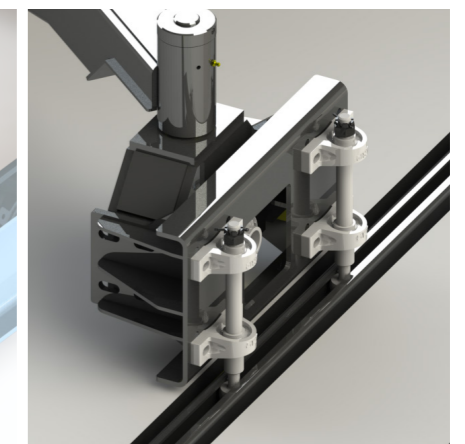

U Front Guided Wheel

See our Design, Project Management and Installation brochure for further information or visit www.coxgomyl.com

Service Solutions

Drawing on a global network, CoxGomyl offers local support in even the most remote locations with all operations carried out by qualified factory-trained service technicians.

The range of service and support solutions available from CoxGomyl include inspections, maintenance & repairs, training, genuine spare parts, asset management programs as well as refurbishment solutions.



SERVICE MAINTENANCE

A comprehensive range of service contracts, maintenance programmes and repair solutions



ASSET MANAGEMENT

A range of support solutions to manage the total life cycle of CoxGomyl and Manntech equipment



GENUINE SPARE PARTS

Genuine spare parts prolong equipment life and maximise performance



REFURBISHMENT SOLUTIONS

Bring new life to aging systems with a cost-effective refurbishment



TRAINING

Training to support the safe operation, maintenance and installation of equipment



INSPECTIONS, SAFETY & COMPLIANCE

Routine inspection programmes to ensure equipment is kept safe and compliant

CoxGomyl offer owners and operators of our equipment, tailored service maintenance agreements specific to their equipment requirements.

Service maintenance can range from ad-hoc maintenance to comprehensive service plans including spare parts and regular maintenance to maintain equipment throughout its lifecycle at a fixed annual cost. Utilising a global service support network, CoxGomyl can respond to callouts promptly.

A range of specific maintenance services are available for the specialised range of products from CoxGomyl, including fully powered building maintenance units, lift tables, monorails, power winch cradles, and fall arrest systems.

For more information visit www.coxgomyl.com

For product and service solution enquiries contact info@coxgomyl.com



Copyright © Alimak Group. All rights reserved.

COXGOMYL and related logos are registered trademarks of Alimak Group AB (publ) and its subsidiaries ("Alimak Group"), in several jurisdictions, including but not limited to the EU and the United States. Alimak Group retains all rights in its name and for above mentioned trademarks, whether registered or not.