



1000 SERIES

ECONOMIC ACCESS SOLUTIONS



*This page: Spain, Madrid, Santiago Bernabeu
Cover: China, HK, CUHK*

Introducing the CoxGomyl 1000 Series Range

Economical Configurations

The CoxGomyl™ 1000 Series range is designed for use on buildings of low complexity, where the building design can be more flexible to accommodate a relatively standard access solution.

When developing concepts using the 1000 Series range, the sales team at CoxGomyl select from a collection of relatively standard equipment, to achieve a simple and economical solution. For more complex facade access requirements that cannot be solved by using the 1000 Series range, the designers at CoxGomyl can always find a suitable solution within the 3000 or 5000 Series range of products for more complex requirements.

CoxGomyl is a leading global provider of premium facade access solutions. Present around the world with over 60 years of experience CoxGomyl has the widest range of configurable building maintenance units built on innovative, proven technologies which provide exceptional performance.

Suspended Platforms

CoxGomyl's 1000 series range of suspended platforms are the ideal choice for safe and efficient facade access for up to three operators and can work in combination with CoxGomyl's monorail system, gantries, and davits to create superior facade access to meet individual building requirements. Our platforms are equipped with a unique self-powered frame including a custom developed traction hoist.

Self-Powered Cradle

CoxGomyl's Self Powered Cradle has been developed for an efficient and safe means of facade access. The cradle has been re-designed and constructed from lightweight aluminium in combination with solid panels and is also available in a single operator option.

Key Features

- Unique self-powered frame including a custom developed traction hoist
- Designed with 7 different length dimensions ranging from 1 to 4 meters
- Suitable for 1-2 operators
- Suitable for indoor and outdoor use
- Light and robust design
- EU components

Select if:

- The shape of the building or the lifting / cradle requirements are not complex
- Looking for the most economical solution
- Required outreach from the front wheels is 0-10m
- Cradle can be used for other systems installed on the buildings
- Building heights up to 150m (depending on local regulations)

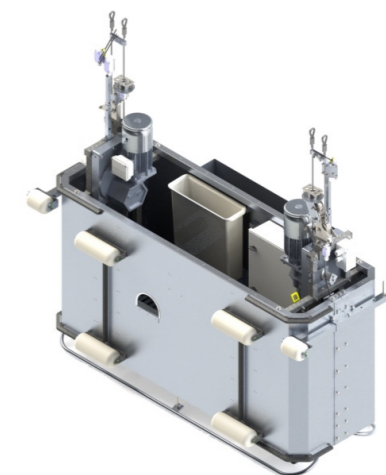

Modular Self Powered Platform

CoxGomyl's Modular Self Powered Platform is the ideal choice for safe and efficient facade access for up to three operators. The platform has been re-designed and constructed from lightweight aluminium in combination with perforated panels. It can be assembled to obtain the platform length required on site thanks to its safety pin system.

Key Features

- Unique self-powered frame including a custom developed traction hoist
- Designed with lengths from 2 to 12 meters using standard modules for multiple configurations
- Suitable for up to 3 operators
- Compact design for easy transport
- Suitable for indoor and outdoor use
- EU components

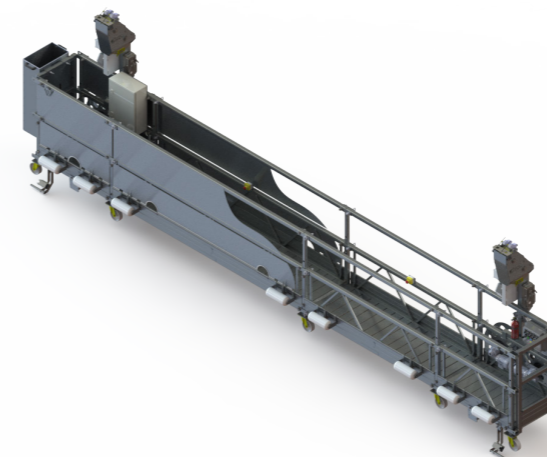

Traversing Trolleys

CoxGomyl's trolleys can be used in combination with our suspended platforms, thanks to the lightweight and robust design, ensuring smooth movement along the monorail tracks. The trolleys are equipped with two suspension holes, one for the suspension wire and one for the safety wire. Select the one that best meets your needs: manual, rope driven and motorized options suitable for straight, curved and inclined monorail tracks.

Manual Trolley

The CoxGomyl CG10RT and CG40RT rope driven trolleys work in combination with the CG10 and CG40 tracks and can be used for indoor and outdoor applications. The trolley is moved by pulling the rope from the suspended self-powered platform. The trolley is equipped with two suspension holes, one for the suspension wire and one for the safety wire. The trolley is for use with straight and curved horizontal tracks only.

Key Features

- Trolley length of 250mm and width of 60mm
- Suitable for indoor and outdoor use
- Constructed from corrosion resistant materials
- Premium bearings for smooth operation
- Optional manual screw brake

Select if:

- The shape of the building or the lifting / cradle requirements are not complex
- Looking for the most economical solution
- Required outreach from the front wheels is 0-3.5m
- Building heights up to 130m



Rope Driven Trolley

The CoxGomyl CG10MT is a manual trolley that works in combination with the CG10 track and can be used for indoor and outdoor applications. The trolley is moved by pulling from the track, pushing from the facade, or moving from the ground level. The trolley is equipped with two suspension holes, one for the suspension wire and one for the safety wire. The trolley is for use with straight and curved horizontal tracks only.

Key Features

- Trolley length of 472mm and width of 75mm
- Suitable for indoor and outdoor use
- Constructed from corrosion resistant materials
- Premium bearings for smooth operation
- Optional manual screw brake

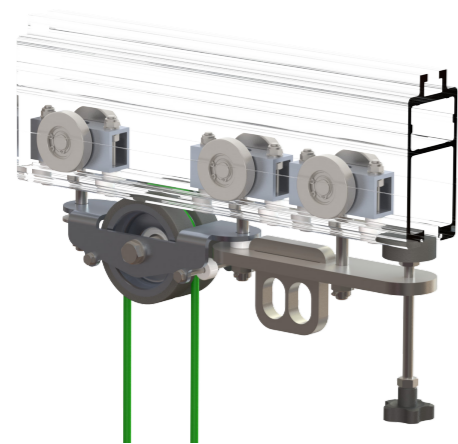

Monorail Tracks

The CoxGomyl monorail system consists of an aluminium track, fixed with steel brackets on the side of the building or underhung in a recess. The system is ideal for buildings that do not allow enough space on the roof slab for a roof-based building maintenance unit, and suitable where large recesses in building elevations cannot be reached with an approaching system within the 5000 Series.

Select if:

- There is not enough space on the roof for a roof-based building maintenance unit
- Looking for the most economical and flexible solution
- There are no projections in the elevation bigger than 0.5m
- Cradle can be used for other systems installed on the building
- Building heights up to 100m (depending on local regulations)

Key Features

- Constructed of aluminium alloy
- Completed with a mill finish
- Available in optional colours of RAL 7022 and RAL 9010
- Available with optional surface treatment of anodizing



CG10



CG20



CG30



CG40

CG10 and CG20

CoxGomyl's CG10 and CG20 monorail tracks are the preferred option when looking for a complete integration in the building design. They can be installed hanging or embedded in the roof ceiling and are suitable for indoor and outdoor installations.

CG30

The CG30 monorail tracks are side mounted and ideal for climbing applications. They can be used in combination with gantries.

CG40

The CG40 monorail tracks are the preferred option when looking for a complete integration in the building design and looking for a solution with a higher distance between brackets or able to work under high loads. They can be installed hanging or embedded in the roof ceiling and are suitable for indoor and outdoor installations.

Turntables

CoxGomyl's concealed CG10 monorail tracks can be equipped with turntables to create intersections of 3 or 4 tracks. The CG10TT Turntables can change direction in a minimum of space covering a greater working area and providing more freedom during design stage.

Key Features

- Suitable for indoor and outdoor use
- Constructed from corrosion resistant materials
- Smooth track transition
- Manual or electrical operation

Select if:

- The preferred method of negotiating corners along monorail systems
- M10 tracks are utilised in the solution

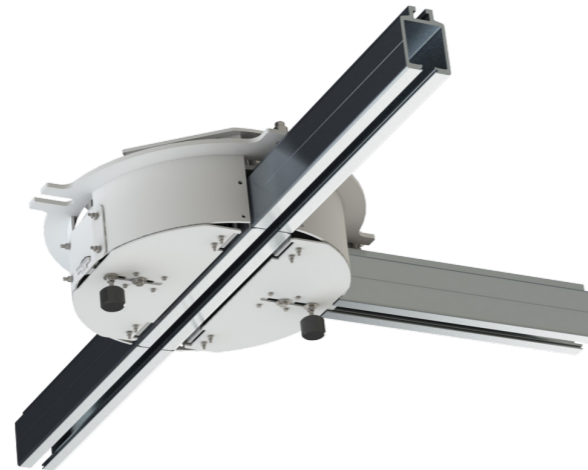

Traction Hoists

The CoxGomyl traction hoist is specifically designed to integrate with CoxGomyl's suspended self-powered platforms or in combination with other lifting equipment.

Key Features

- Easy to maintain
- Long life cycle
- Designed for heavy duty use

Select if:

- A self-powered platforms is utilised in the solution
- Adverse climatic conditions are of concern

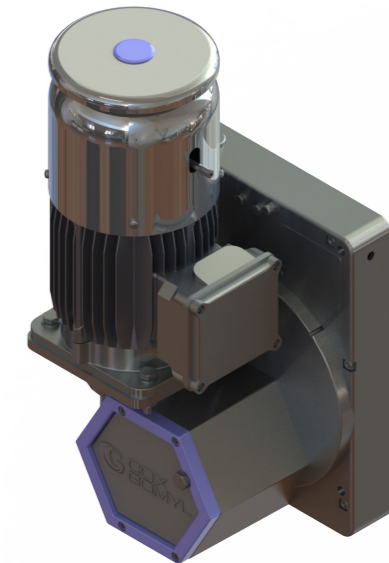

Davits

The Davit system is one of the most cost-effective systems for facade access. The davit system can be used to support the self-powered cradle, used by abseilers to position in front of the facade or to lift materials during panel replacement.

Key Features

- Davits can achieve a maximum reach from centre of base of 2.5m

Select if:

- There is not enough space on the roof for a roof-based machine
- Looking for the most economical solution with no visual impact when not in use
- Cradle can be used for other systems installed on the building
- Building heights up to 100m (depending on local regulations)



Copyright © Alimak Group. All rights reserved.



Copyright © Alimak Group. All rights reserved.

Service Solutions

Drawing on a global network, CoxGomyl offers local support in even the most remote locations with all operations carried out by qualified factory-trained service technicians.

The range of service and support solutions available from CoxGomyl include inspections, maintenance & repairs, training, genuine spare parts, asset management programs as well as refurbishment solutions.



SERVICE MAINTENANCE

A comprehensive range of service contracts, maintenance programmes and repair solutions



ASSET MANAGEMENT

A range of support solutions to manage the total life cycle of CoxGomyl and Manntech equipment



GENUINE SPARE PARTS

Genuine spare parts prolong equipment life and maximise performance



REFURBISHMENT SOLUTIONS

Bring new life to aging systems with a cost-effective refurbishment



TRAINING

Training to support the safe operation, maintenance and installation of equipment



INSPECTIONS, SAFETY & COMPLIANCE

Routine inspection programmes to ensure equipment is kept safe and compliant

CoxGomyl offer owners and operators of our equipment, tailored service maintenance agreements specific to their equipment requirements.

Service maintenance can range from ad-hoc maintenance to comprehensive service plans including spare parts and regular maintenance to maintain equipment throughout its lifecycle at a fixed annual cost. Utilising a global service support network, CoxGomyl can respond to callouts promptly.

A range of specific maintenance services are available for the specialised range of products from CoxGomyl, including fully powered building maintenance units, lift tables, monorails, power winch cradles, and fall arrest systems.

For more information visit www.coxgomyl.com

For product and service solution enquiries contact info@coxgomyl.com



COXGOMYL and related logos are registered trademarks of Alimak Group AB (publ) and its subsidiaries ("Alimak Group"), in several jurisdictions, including but not limited to the EU and the United States. Alimak Group retains all rights in its name and for above mentioned trademarks, whether registered or not.